

### Schafffräser VHM

Universal, HPC für Schlichtarbeiten



	<b>P</b> N/mm <sup>2</sup>	<b>M</b> N/mm <sup>2</sup>	<b>K</b> HB
175633	(1500)	(1000)	(800)
vc = m/min.			
175633	240-475	120-195	215-520

VHM beschichtet Werksnorm

Zähne 7 3 x A1 45° Drall

6355 HA-Schaft lang

UNI HPC

**Ausführung:**  
Zum Umfangfräsen als Schlichtbearbeitungsgang zur Erzeugung höchster Oberflächengüte.



Art.-Nr.	175633 3 x A1, lang, beschichtet (RG 1734)	A1 mm	B2 mm	B5 mm	C3 mm	Z	fz mm/Zahn
6,00	73,90	6	18	62	6	7	0,028-0,095
8,00	96,75	8	24	68	8	7	0,036-0,123
10,00	124,40	10	30	80	10	7	0,043-0,149
12,00	164,00	12	36	93	12	7	0,050-0,174
16,00	262,20	12	48	108	16	7	0,063-0,217
20,00	424,40	20	60	126	20	7	0,073-0,252

### Schafffräser VHM

HRC, für Schlichtarbeiten



	<b>P</b> N/mm <sup>2</sup>	<b>H</b> HRC	<b>K</b> HB
175605	(1200)	(62)	(350)
vc = m/min.			
175605	160-190	50-75	130-330

VHM beschichtet DIN 6527

Typ N Zähne 6-8 45° Drall

6355 HB-Schaft kurz

H



Art.-Nr.	175605 kurz, Fase, X-CEED (RG 1731)	A1 mm	B2 mm	B5 mm	C3 mm	G2 mm	Z	fz mm/Zahn
5,0	49,80	5	10	54	6	0,1	6	0,010-0,025
6,0	49,80	6	10	54	6	0,1	6	0,013-0,033
8,0	68,65	8	12	58	8	0,1	6	0,019-0,047
10,0	91,30	10	14	66	10	0,1	6	0,019-0,047
12,0	124,30	12	16	73	12	0,15	6	0,030-0,072
16,0	209,70	16	20	82	16	0,2	8	0,038-0,088

### Schafffräser VHM HRC



	<b>H</b> HRC
175600	(62)
175602	(70)
vc = m/min.	
175600	100-200
175602	80-150

**Toleranz**

Durchmesserbereich	Schneiden-Ø Ø A1 (g7)	Schaft-Ø Ø C3 (h5)
A1 ≤ 3	-0,002 -0,012	0 -0,004
3 < A1 ≤ 6	-0,004 -0,016	0 -0,005
6 < A1 ≤ 10	-0,005 -0,020	0 -0,006
10 < A1 ≤ 18	-0,006 -0,024	0 -0,008
18 < A1 ≤ 30	-0,007 -0,028	0 -0,009

VHM beschichtet Werksnorm Zähne 6 45° Drall

6355 HA-Schaft kurz HPM HSM

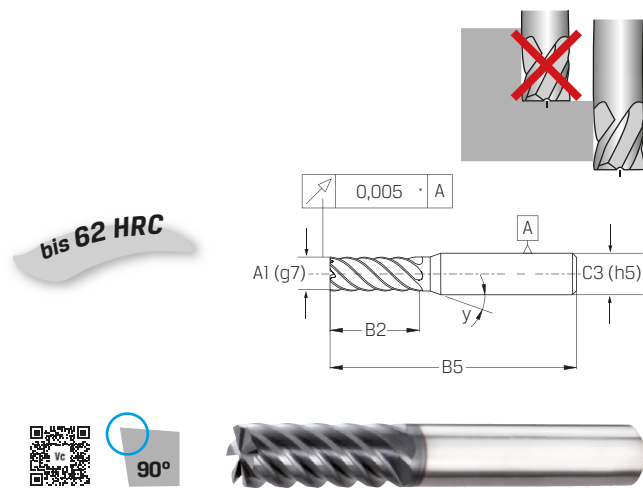

Art.-Nr.	175600 kurz, TiAlN (RG 1750)	A1 mm	B2 mm	B5 mm	C3 mm	y	Z	fz mm/Zahn
3,00	108,70	3	10	65	6	15	6	0,020-0,035
4,00	106,30	4	10	65	6	15	6	0,030-0,045
5,00	104,00	5	15	65	6	15	6	0,030-0,055
6,00	101,20	6	20	65	6	-	6	0,045-0,065
8,00	138,00	8	20	65	8	-	6	0,060-0,080
10,00	174,90	10	25	70	10	-	6	0,070-0,095
12,00	192,00	12	25	79	12	-	6	0,085-0,110
16,00	292,90	16	35	90	16	-	6	0,095-0,125

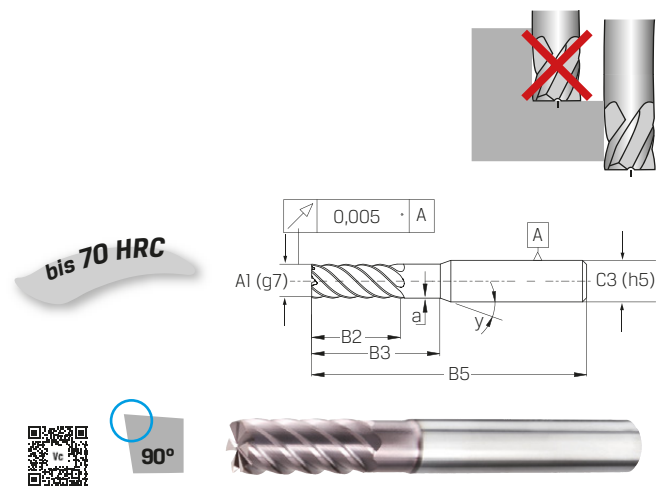

Art.-Nr.	175602 kurz, TiAlN (RG 1750)	A1 mm	B2 mm	B3 mm	B5 mm	C3 mm	a mm	y	Z	fz mm/Zahn
3,00	119,50	3	8	15	65	6	0,05	15	6	0,020-0,035
4,00	116,90	4	10	16	65	6	0,1	15	6	0,030-0,045
5,00	114,30	5	12	18	65	6	0,15	15	6	0,030-0,055
6,00	111,40	6	14	20	65	6	0,2	-	6	0,045-0,065
8,00	151,80	8	18	25	79	8	0,2	-	6	0,060-0,080
10,00	192,40	10	22	30	79	10	0,3	-	6	0,070-0,095
12,00	211,10	12	26	35	90	12	0,3	-	6	0,085-0,110
16,00	322,10	16	34	-	90	16	-	-	6	0,095-0,125