

Winkelstirnfräser

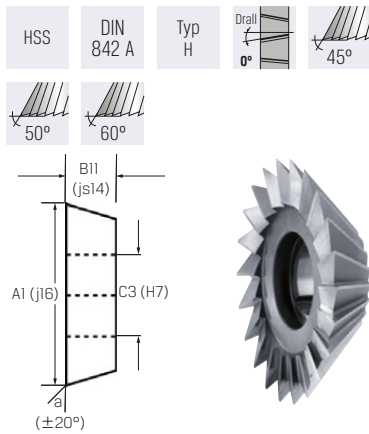

	<b>P</b> N/mm <sup>2</sup>	<b>K</b> HB
156450	(850)	(240)
156500	(850)	(240)
156600	(850)	(240)
vc = m/min.		
156450	26-30	17-25
156500	26-30	17-25
156600	26-30	17-25



**Verwendung:**  
Fräsen von geraden Nuten (Längsnut nach DIN 138) und Führungen.



Art.-Nr.	156450 45° (RG 1503)	156500 50° (RG 1503)	156600 60° (RG 1503)	A1 mm	B11 mm	C3 mm	Z	fz mm/Zahn
50x13x13	107,50	-	-	50	13	13	16	0,030-0,033
50x16x13	-	107,50	107,50	50	13	13	16	0,030-0,033
63x18x16	114,80	-	-	63	16	16	18	0,035-0,039
63x20x16	-	114,80	114,80	63	16	16	18	0,035-0,039
80x22x22	182,30	-	-	80	22	22	20	0,040-0,044
80x25x22	-	182,30	182,30	80	22	22	20	0,040-0,044
100x28x27	298,50	-	-	100	28	27	22	0,045-0,050
100x32x27	-	298,50	298,50	100	28	27	22	0,045-0,050

Prismenfräser



	<b>P</b> N/mm <sup>2</sup>	<b>K</b> HB
156700	(850)	(240)
156720	(850)	(240)
156750	(850)	(240)
vc = m/min.		
156700	26-30	17-25
156720	26-30	17-25
156750	26-30	17-25

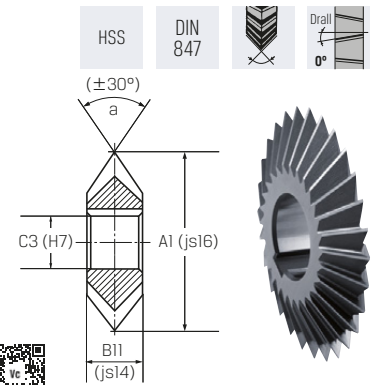

Art.-Nr.	156700 45° (RG 1503)	156720 60° (RG 1503)	156750 90° (RG 1503)	A1 mm	B11 mm	C3 mm	Z	fz mm/Zahn
50x8	108,50	-	-	50	8	16	22	0,033-0,030
50x10	-	114,00	-	50	10	16	18	0,033-0,030
50x14	-	-	119,60	50	14	16	16	0,033-0,030
63x10	129,60	-	-	63	10	22	24	0,039-0,035
63x14	-	136,20	-	63	14	22	20	0,039-0,035
63x20	-	-	142,90	63	20	22	18	0,039-0,035
80x12	155,30	-	-	80	12	27	26	0,044-0,040
80x18	-	163,20	-	80	18	27	22	0,044-0,040
80x22	-	-	171,20	80	22	27	20	0,044-0,040
100x18	268,80	-	-	100	18	32	28	0,050-0,045
100x25	-	277,30	-	100	25	32	24	0,050-0,045
100x32	-	-	286,20	100	32	32	24	0,050-0,045

Profilfräser



	<b>P</b> N/mm <sup>2</sup>	<b>K</b> HB
156800	(850)	(240)
vc = m/min.		
156800	26-30	17-25

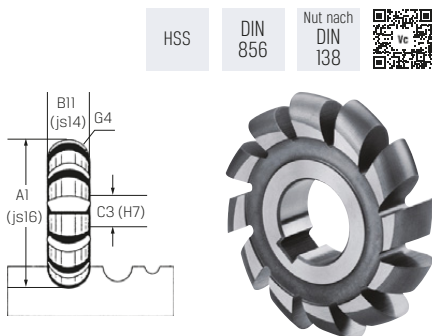

**Ausführung:**  
- geradeverzahnt  
- radial hinterdreht  
- 8° Spanwinkel

Art.-Nr.	156800 halbrund, konvex (RG 1503)	G4 mm	A1 mm	B11 mm	C3 mm	Z	fz mm/Zahn
1,0	109,40	1	50	2	16	14	0,080-0,088
1,6	109,40	1,6	50	3,2	16	14	0,080-0,088
2,0	109,40	2	50	4	16	14	0,080-0,088
2,5	108,50	2,5	63	5	22	12	0,100-0,111
3,0	112,10	3	63	6	22	12	0,100-0,111
4,0	119,60	4	63	8	22	12	0,100-0,111
5,0	159,30	5	63	10	22	12	0,100-0,111
6,0	185,10	6	80	12	27	12	0,120-0,132
8,0	224,50	8	80	16	27	12	0,120-0,132

	<b>P</b> N/mm <sup>2</sup>	<b>K</b> HB
156850	(850)	(240)
vc = m/min.		
156850	26-30	17-25

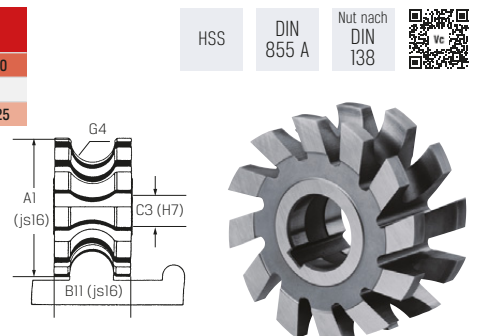

**Ausführung:**  
- geradeverzahnt  
- radial hinterdreht  
- 8° Spanwinkel

Art.-Nr.	156850 halbrund, konvex (RG 1503)	G4 mm	A1 mm	B11 mm	C3 mm	Z	fz mm/Zahn
1,0	114,80	1	50	6	16	14	0,080-0,088
2,0	114,80	2	50	9	16	14	0,080-0,088
2,5	118,10	2,5	63	10	22	12	0,100-0,110
3,0	122,10	3	63	12	22	12	0,100-0,110
4,0	130,50	4	63	16	22	12	0,100-0,110
5,0	173,70	5	63	20	22	12	0,100-0,110
6,0	201,80	6	80	24	27	12	0,120-0,132
8,0	244,40	8	80	32	27	12	0,120-0,132

Zahnformfräser



	<b>P</b> N/mm <sup>2</sup>	<b>K</b> HB
156961	(850)	(350)
vc = m/min.		
156961	15-20	10-12

**Ausführung:**  
- hinterdreht  
- Eingriffswinkel 20°

**Verwendung:**  
Zum Fräsen von Stirnrädern nach Modul.

**Bestell-Beispiel: 156961 2,0/3**  
(Fräser mit Modul 2,0 und für Zähnezahl 17-20)

HSS	DIN 6513	Profil DIN 3972	
-----	----------	-----------------	--

Modul/ Fräser-Nr.	156961 HSS-Co einzeln (RG 1500)	A1 mm	C3 mm
0,5/1 - 0,5/8	120,20	40	16
1,0/1 - 1,0/8	130,40	50	16
1,5/3 - 1,5/8	145,80	63	22
2,0/3 - 2,0/8	157,80	63	22
2,5/8 - 2,5/8	177,60	63	22
3,0/4 - 3,0/8	200,10	70	27
4,0/3 - 4,0/4	287,40	80	27

Fräser Nr.	1	2	3	4	5	6	7	8
Für Zähnezahl	12-13	14-16	17-20	21-25	26-34	35-54	55-134	135-Zahnstange

