

Schrupfräser HSS-Co Universal **PREMUS®**

	P	M	K	S	HSS-Co	DIN	Typ
	N/mm ²	N/mm ²	HB	N/mm ²		844	NR
167401	<1000	<850	<240	Titan	Zähne 4-5	30° Drall	Zentrumschnitt
167501	<1000	<850	<240	Titan <1200			
vc = m/min.							
167401	12-40	18-25	20-30	5-15	Schnittdaten	1835 B-Schaft	lang
167501	25-65	35-45	35-55	10-25			

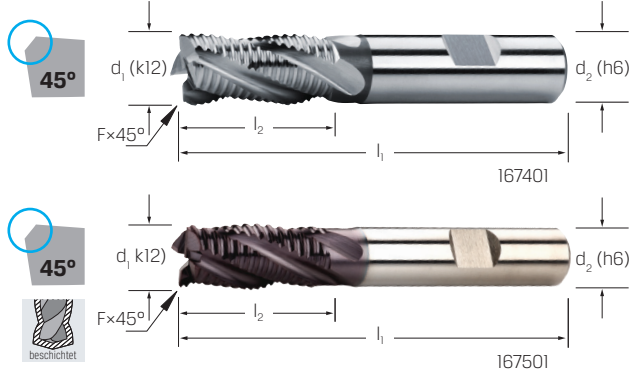

d ₁ mm	167401 (RG 1600)	167501 TiAlN (RG 1600)	l ₁ mm	l ₂ mm	d ₂ mm	Z	fz mm/Zahn
6,00	15,55	19,25	57	13	6	4	0,006-0,013
8,00	17,15	22,00	69	19	10	4	0,010-0,019
10,00	19,55	24,95	72	22	10	4	0,013-0,025
12,00	23,00	29,45	83	26	12	4	0,016-0,030
14,00	27,70	36,30	83	26	12	4	0,016-0,030
16,00	32,50	41,10	92	32	16	4	0,020-0,038
18,00	37,80	48,45	92	32	16	4	0,020-0,038
20,00	46,80	58,65	104	38	20	4	0,023-0,045
22,00	57,80	69,25	104	38	20	5	0,023-0,045
25,00	68,75	83,60	121	45	25	5	0,023-0,045

Schrupfräser HSS-Co Universal **PREMUS®**

	P	M	K	S	N	HSS-Co	DIN	Typ
	N/mm ²	N/mm ²	HB	N/mm ²	N/mm ²		844	NR
167901	<1000	<850	<240	Titan <1200	Alu <600 Messing <600	Zähne 4-6	30° Drall	Zentrumschnitt
167906	<1000	<850	<240	Titan <1200				
vc = m/min.								
167901	10-35	15-25	20-30	5-15	Schnittdaten	1835 B-Schaft	extra lang	UNI
167906	20-60	30-40	35-50	10-25				

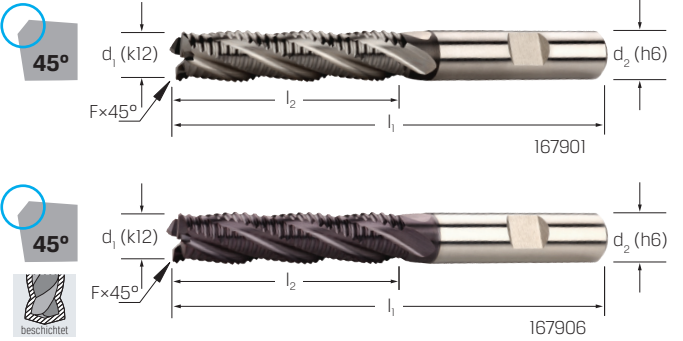

d ₁ mm	167901 (RG 1605)	167906 TiAlN (RG 1605)	l ₁ mm	l ₂ mm	d ₂ mm	Z	fz mm/Zahn
10,00	33,45	41,05	95	45	10	4	0,013-0,021
12,00	39,25	48,50	110	53	12	4	0,016-0,026
14,00	46,65	57,40	110	53	12	4	0,016-0,026
16,00	55,55	67,75	123	63	16	4	0,020-0,032
18,00	66,40	82,30	123	63	16	4	0,020-0,032
20,00	82,25	97,20	141	75	20	4	0,023-0,038
22,00	98,80	118,20	141	75	20	5	0,023-0,038
25,00	120,90	142,90	166	90	25	5	0,023-0,038
30,00	177,60	204,10	166	90	25	5	0,023-0,038
32,00	199,90	228,10	186	106	32	6	0,023-0,038

Schrupfräser HSS-Co Universal **PREMUS®**

	P	M	K	S	HSS-Co	DIN	Typ
	N/mm ²	N/mm ²	HB	N/mm ²		844	NF
165001	<1000	<850	<240	Titan <1200	Zähne 4-5	30° Drall	Zentrumschnitt
165006	<1000	<850	<240	Titan <1200			
vc = m/min.							
165001	12-35	18-25	20-30	5-15	Schnittdaten	1835 B-Schaft	lang
165006	25-65	35-45	35-55	10-25			

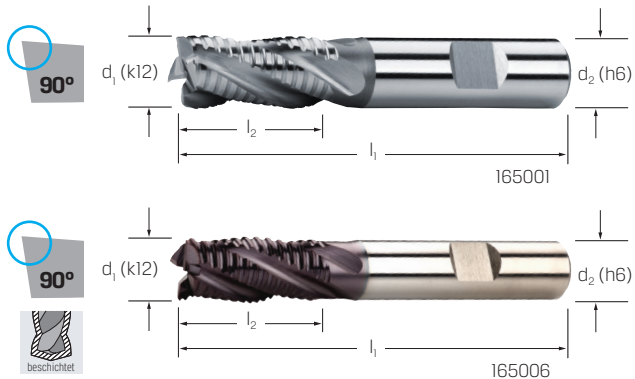

d ₁ mm	165001 (RG 1602)	165006 TiAlN (RG 1602)	l ₁ mm	l ₂ mm	d ₂ mm	Z	fz mm/Zahn
6,00	20,30	24,90	57	13	6	4	0,006-0,013
8,00	22,30	28,50	69	19	10	4	0,010-0,019
9,00	25,40	-	69	19	10	4	0,010-0,019
10,00	25,40	33,10	72	22	10	4	0,013-0,025
12,00	29,85	39,10	83	26	12	4	0,016-0,030
14,00	36,05	46,80	83	26	12	4	0,016-0,030
16,00	42,55	54,85	92	32	16	4	0,020-0,038
18,00	48,65	64,85	92	32	16	4	0,020-0,038
20,00	59,65	78,00	104	38	20	4	0,023-0,045
22,00	71,65	92,10	104	38	20	5	0,023-0,045
25,00	87,65	111,20	121	45	25	5	0,023-0,045

Radiusfräser HSS-Co Universal **PREMUS®**

	P	M	K	S	N	HSS-Co	Werk-norm	Zähne
	N/mm ²	N/mm ²	HB	N/mm ²	N/mm ²			2
168881	<1000	<850	<240	Titan <1200	Alu <600 Messing <600	Zähne 2	1835 B-Schaft	UNI
168886	<1000	<850	<240	Titan <1200				
vc = m/min.								
168881	10-30	10-20	10-20	5-12	35-150	30-60	Schnittdaten	kurz
168886	20-60	30-40	35-50	10-25	100-210	75-100		

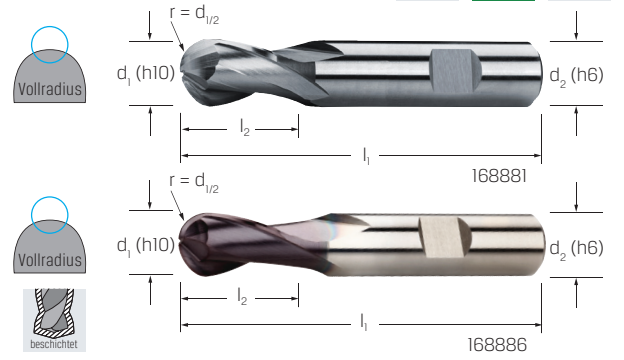

d ₁ mm	168881 (RG 1606)	168886 TiAlN (RG 1605)	r mm	l ₁ mm	l ₂ mm	d ₂ mm	fz mm/Zahn
3,00	18,30	20,15	1,5	49	5	6	0,003-0,007
4,00	18,30	20,15	2,0	51	7	6	0,006-0,010
5,00	18,30	21,05	2,5	52	8	6	0,007-0,014
6,00	18,85	22,45	3,0	52	8	6	0,009-0,017
8,00	23,00	27,95	4,0	61	11	10	0,014-0,024
10,00	26,90	33,25	5,0	63	13	10	0,018-0,030
12,00	31,20	39,00	6,0	73	16	12	0,022-0,035
14,00	38,75	47,60	7,0	73	16	12	0,022-0,035
16,00	44,90	54,90	8,0	79	19	16	0,027-0,045
18,00	55,40	66,25	9,0	79	19	16	0,027-0,045
20,00	69,10	80,50	10,0	88	22	20	0,033-0,056
22,00	83,60	95,50	11,0	88	22	20	0,033-0,056
25,00	100,30	125,90	12,5	102	26	25	0,033-0,056
28,00	123,00	136,70	14,0	102	26	25	0,033-0,056
30,00	137,20	151,40	15,0	102	26	25	0,033-0,056